

Hot Food Slide

Hot Food Slides are extensively used throughout Australian canteens and self serve food sales outlets. Culinaire units have a proven reputation to perform in large crowd venues of major stadiums such as skilled stadium.

Culinaire Hot Food Slides are available in a range of standard sizes. Custom lengths can also be ordered for a premium.

Models:

SPHE.HFS.A.X.L

Where:

SPHE =	Standard Product Heated
HFS =	Hot Food Slide
A =	Angled Slides
X =	1 = single slide 2 = double slide
L =	Length
Std Lengths	900mm, 1200mm, 1500mm

e.g.: SPHE.HFS.A.1.1500

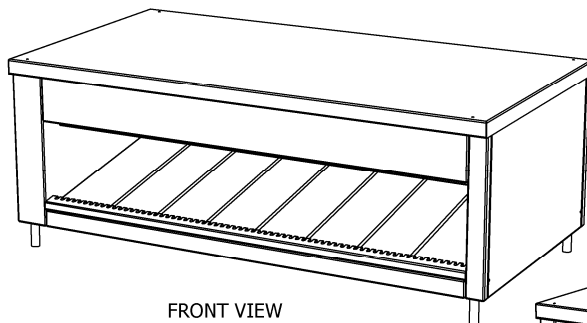

FRONT VIEW

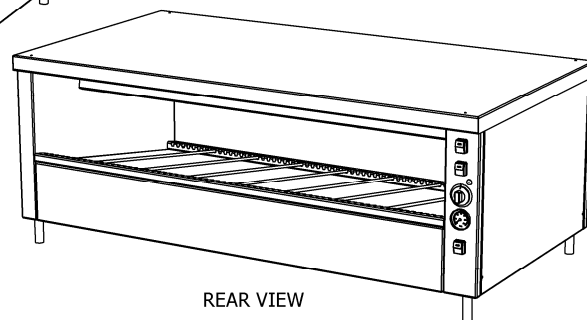

REAR VIEW

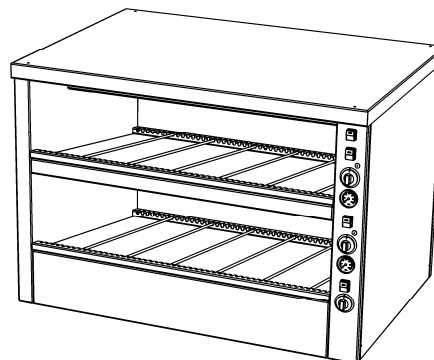
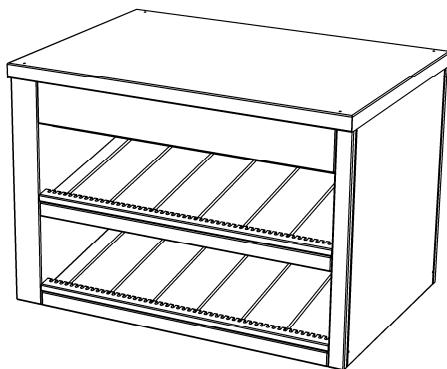

Features and Benefits:

- Manufactured from 1.2mm thick No. 4 finish 304 grade stainless steel.
- Heavy duty 8mm diameter stainless steel product divider bars. Adjustable in 20mm increments.
- Removable product divider bars holders ensure unrestricted access for easy cleaning.
- Heavy duty push button on/off switches to operate lighting.
- Heavy duty push button on/off switches to operate each product shelf.
- Heavy duty German made individual temperature controls to each product shelf for perfect product presentation.
- Supplied with 2m of flex for connection to power supply.
- Note: Isolating switch is to be supplied and fitted in close proximity by the installing electrician (as required by Australian Electrical legislation)
- Unit is tested to Australian Std AS3760 and manufactured in accordance with AS/NZS 60633.1

Due to continuous product research and development, the information contained herein is subject to change without notification.

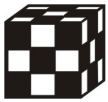

Hot Food Slide

Angled Double Hot Food Slide

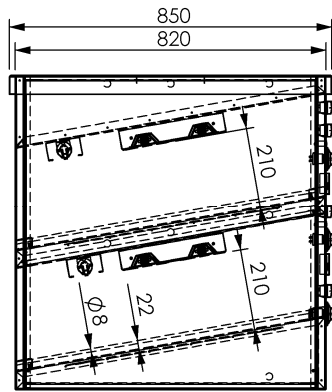

Models:

SPHE.HFS.A.X.L

Where:

- SPHE = Standard Product Heated
- HFS = Hot Food Slide
- A = Angled Slides
- X = 1 = single slide
2 = double slide
- L = Length
Std Lengths 900mm, 1200mm, 1500mm

e.g.: SPHE.HFS.A.1.1500

Angled Single Hot Food Slide

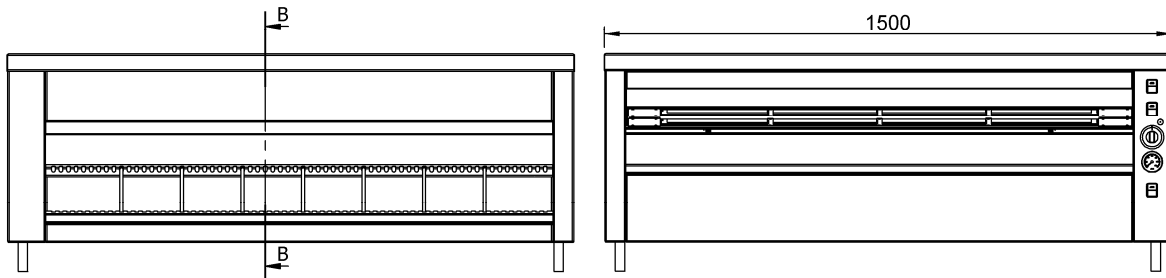
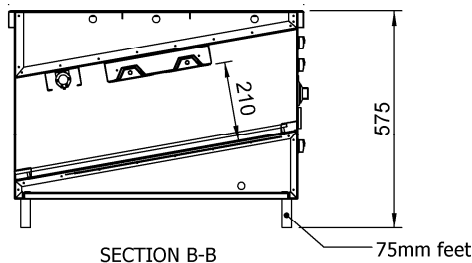

Equipment Data								
Model	Length (mm)	Height (mm)	Fluorescent Lights	Overhead Heater Elements (watts)	Surface Heaters (watts)	Total Electrical Load (Watts)	415 v 3A + N + E Amps/phase	Weight (kg)
SPHE.HFS.A.1.900	900 mm	575 mm	1 x 30w	2 x 750	1 x 350	1900	2.75	
SPHE.HFS.A.1.1200	1200 mm	575 mm	1 x 30w	2 x 1000	2 x 350	2800	4	
SPHE.HFS.A.1.1500	1500 mm	575 mm	1 x 36w	2 x 1000	3 x 350	3100	4.5	
SPHE.HFS.A.2.900	900 mm	830 mm	2 x 30w	4 x 750	2 x 350	3800	5.5	
SPHE.HFS.A.2.1200	1200 mm	830 mm	2 x 30w	4 x 1000	4 x 350	5600	7.5	
SPHE.HFS.A.2.1500	1500 mm	830 mm	2 x 30w	4 x 1000	6 x 350	6200	9	

Note All units are 850 mm standard depth (front to back)

Due to continuous product research and development, the information contained herein is subject to change without notification.