

Hot Dog Warmer Bench

Hot Dog Warmer Benches are valuable income producers in Australian canteens and self serve food sales outlets.

Culinaire units have a proven reputation to perform in large crowd venues of major stadiums such as skilled stadium.

Culinaire Hot Dog Warmer Benches are available in Left or Right Hand Configurations. Custom lengths can also be ordered for a premium.

Models:

SPHE.HDWB.X.L.W

Where:

SPHE = Standard Product Heated

HDWB = Hot Dog Warmer Bench

X = Warmer unit position
(L) Left, (R) Right, (C) Centre

L = Length
(Std 1200mm, 1600mm, 2000 mm)

W = Width
(std 800 mm)

e.g.: SPHE.HDWB.R.1600.800

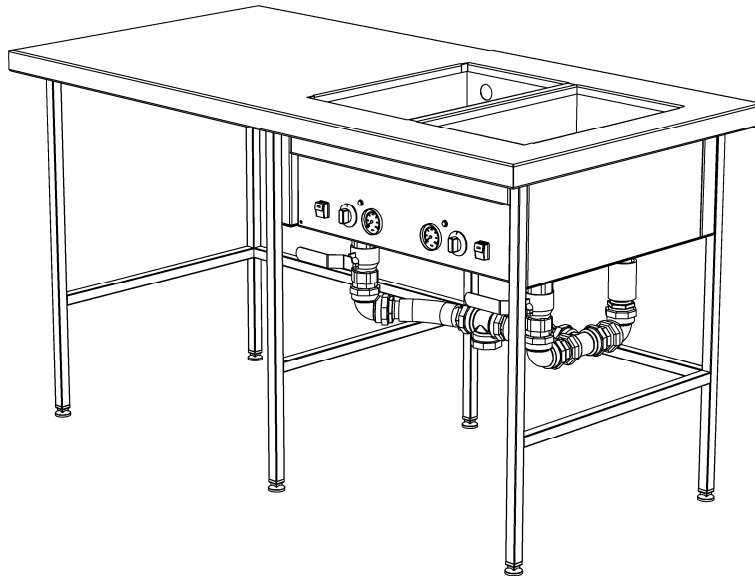

Features and Benefits:

- Manufactured from 1.2mm thick No. 4 finish 304 grade stainless steel.
- Heavy duty 8mm diameter stainless steel product dividers bars. Adjustable in 20mm increments.
- Removable product divider bars holders ensure unrestricted access for easy cleaning.
- Heavy duty push button on/off switches to operate lighting.
- Heavy duty push button on/off switches to operate each product shelf.
- Heavy duty German made individual temperature controls to each product shelf for perfect product presentation.
- Supplied with 2m of flex for connection to power supply.
- Note: Isolating switch is to be supplied and fitted in close proximity by the installing electrician (as required by Australian Electrical legislation)
- Unit is tested to Australian Std AS3760 and manufactured in accordance with AS/NZS 60633.1

Due to continuous product research and development, the information contained herein is subject to change without notification.

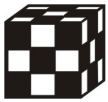

Hot Dog Warmer Bench

Models:

SPHE.HDWB.X.L.W

Where:

SPHE = Standard Product Heated

HDWB = Hot Dog Warmer Bench

X = Warmer unit position
(L) Left, (R) Right, (C) Centre

L = Length
(Std 1200mm, 1600mm, 2000 mm)

W = Width
(std 800 mm)

e.g.: SPHE.HDWB.R.1600.800

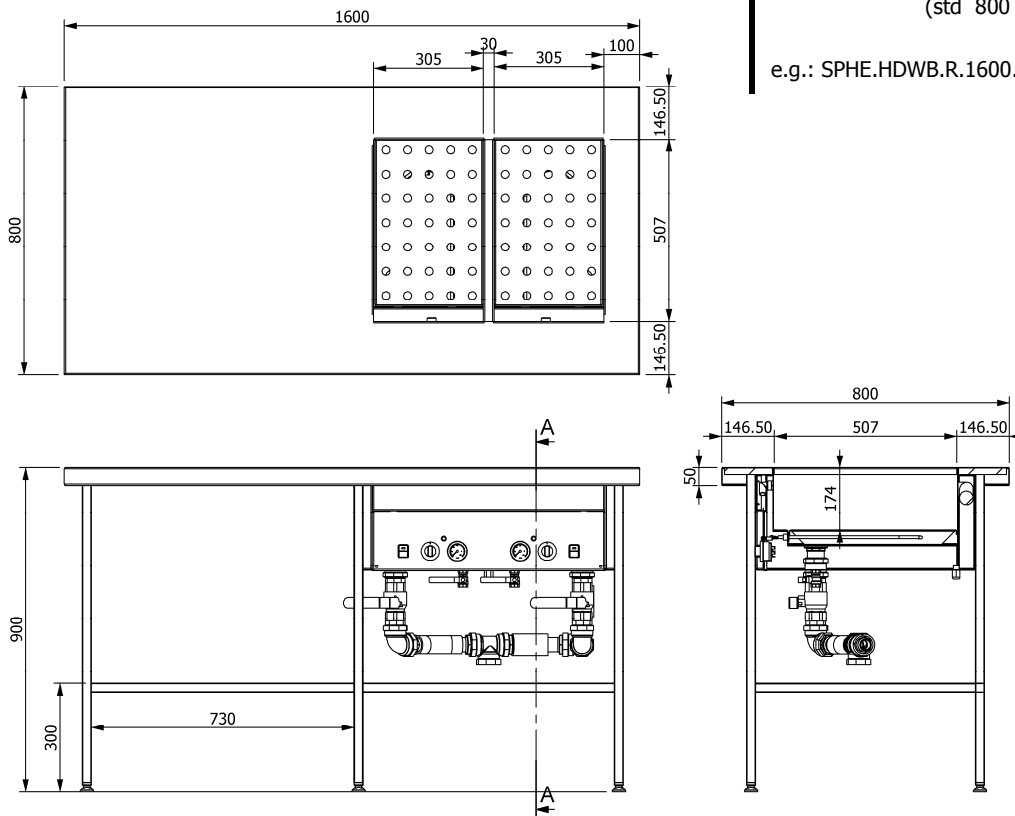

Specifications:

- Manufactured from 1.2mm thick No. 4 finish 304 grade stainless steel.
- Electrical Connection: 240V, 15A 3.6kW – must be hard wired.
- Power: Two heating elements @ 1800 W each.
- Waste: 40mm with 1/2" BSP ball valve
- Overflow: 38mm I.D. flexible hose
- Water Connection: 1/2" BSP ball valve
- Unit Controls: Switch for each bain marie with simmerstat control and "Power On" Light.

Due to continuous product research and development, the information contained herein is subject to change without notification.