



### Box Hood Type 2

The Culinaire® range of kitchen exhaust hoods brings into one brand, Australian designed and manufactured exhaust hood products that comply with Australian Standards AS 1668.2 and have over 20 years of successful sales history.

The Culinaire® exhaust hoods include Box Hoods, V Bank type and Tapered type along with models that incorporate make up air grills.

The exhaust hood can be fitted with either aluminium mesh, honeycomb filters or stainless steel baffle filters. (Please order the required filters with the exhaust hood)

**Models:**

**SPEH.BH.T2.xxxx.yyyy.zzzz.S**  
**SPEH.BH.T2.xxxx.yyyy.zzzz.G**

Code explanation:

SPEH = Standard Product Exhaust Hood

T2 = Type 2

xxxx = Length of Hood

1100 = Width of Hood 1100mm

1050 = Height 1050mm

SS = Stainless Steel

G = Galvanised Steel

e.g.: for specification and ordering

Culinaire SPEH.BH.T2.1500.1100.1050.SS

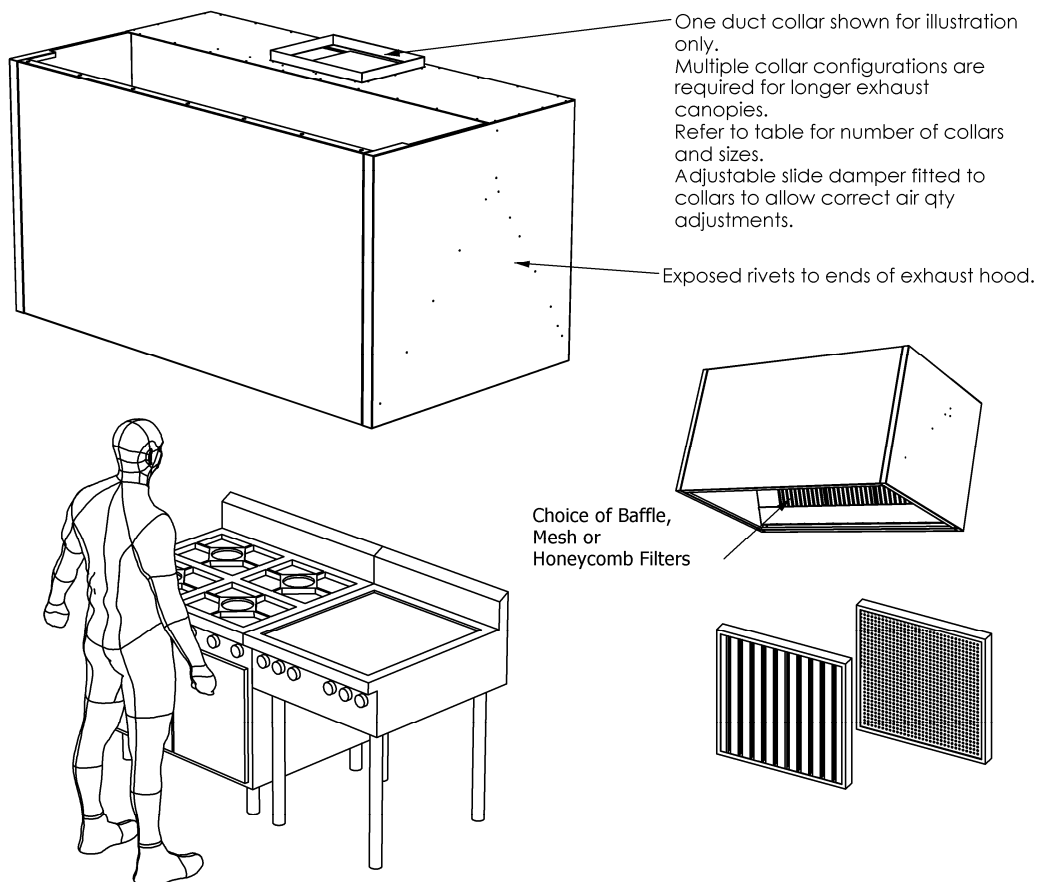
**Features and Benefits:**

- The hood is manufactured from 1.2mm thick Stainless Steel, 304 grade with No. 4 finish to be rigid & corrosive resistant.
- The hood can be ordered in 1.2mm Galvanised Steel for budget applications where visual appearance is not a criteria
- An Engineer's certification can be supplied to demonstrate that the construction complies with Australian Standard AS1668.2.
- A fully welded grease gutter is integral with the perimeter of the exhaust hood.
- A grease gutter plug is located at each end of the wall side of the exhaust hood gutter for periodic cleaning or for connection to drain.
- One or more (dependant on the length of the hood) sealed fluorescent lighting systems are standard.
- The lights are accessible from inside the exhaust hood via a hinged stainless steel and 6mm thick safety glass cover.
- The exhaust hood can be fitted with either aluminium mesh filters or stainless steel baffle filters. (Ordered separately)
- Large filters (495mm x 495mm) minimise filter cleaning frequency whilst still allowing them to fit into most dishwashers.

Due to continuous product research and development, the information contained herein is subject to change without notification.



## Box Hood Type 2

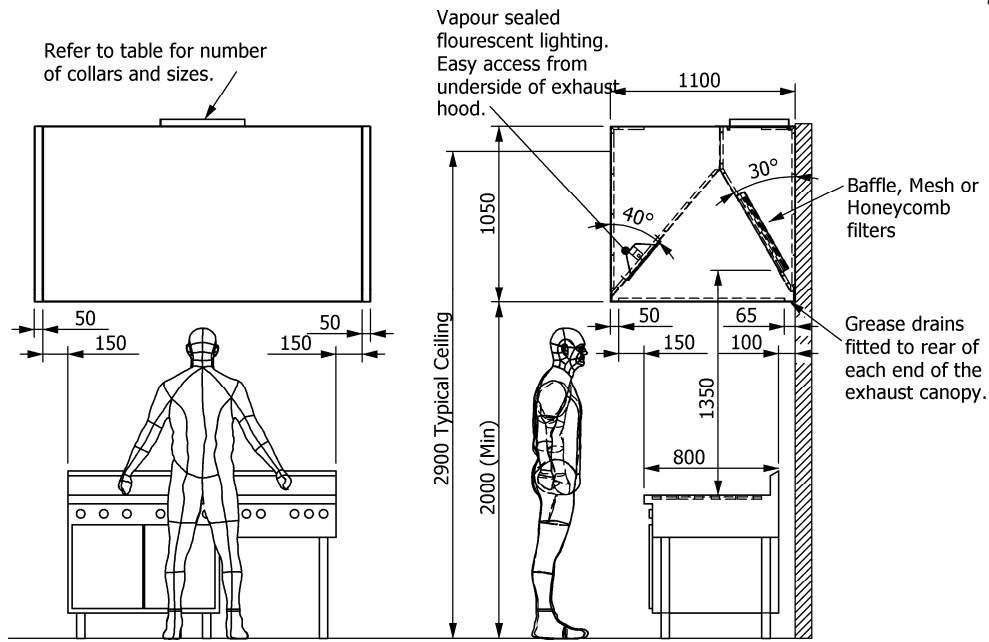

**Hood Data – Hood mounted against the wall.**

Hood resistance = 80pa – Mesh Filters Clean  
120pa – Baffle Filters

Part Id	Length (mm)	Width (mm)	Height (mm)	Req. Air Qty			Collar Size		No.	Lights
				Boiling (l/s)	Frying (l/s)	BBQ (l/s)	Width (mm)	Length (mm)		
SPEH.BH.T2.1500.1100.1050	1500	1100	1050	562.4	740	1110	300	500	1	1 x 30w
SPEH.BH.T2.1600.1100.1050	1600	1100	1050	577.6	760	1140	300	500	1	1 x 36w
SPEH.BH.T2.1700.1100.1050	1700	1100	1050	592.8	780	1170	300	500	1	1 x 36w
SPEH.BH.T2.1800.1100.1050	1800	1100	1050	608	800	1200	300	500	1	1 x 36w
SPEH.BH.T2.1900.1100.1050	1900	1100	1050	623.2	820	1230	300	500	2	1 x 36w
SPEH.BH.T2.2000.1100.1050	2000	1100	1050	638.4	840	1260	300	500	2	1 x 36w
SPEH.BH.T2.2100.1100.1050	2100	1100	1050	653.6	860	1290	300	500	2	1 x 36w
SPEH.BH.T2.2200.1100.1050	2200	1100	1050	668.8	880	1320	300	500	2	1 x 36w
SPEH.BH.T2.2300.1100.1050	2300	1100	1050	684	900	1350	300	500	2	1 x 36w
SPEH.BH.T2.2400.1100.1050	2400	1100	1050	699.2	920	1380	300	500	2	1 x 36w
SPEH.BH.T2.2500.1100.1050	2500	1100	1050	720	960	1440	300	500	2	1 x 36w
SPEH.BH.T2.2600.1100.1050	2600	1100	1050	750	1000	1500	300	500	2	1 x 36w
SPEH.BH.T2.2700.1100.1050	2700	1100	1050	780	1040	1560	300	500	2	1 x 36w
SPEH.BH.T2.2800.1100.1050	2800	1100	1050	810	1080	1620	300	500	2	2 x 36w
SPEH.BH.T2.2900.1100.1050	2900	1100	1050	840	1120	1680	300	500	2	2 x 36w
SPEH.BH.T2.3000.1100.1050	3000	1100	1050	870	1160	1740	300	500	2	2 x 36w
SPEH.BH.T2.3100.1100.1050	3100	1100	1050	900	1200	1800	300	500	2	2 x 36w
SPEH.BH.T2.3200.1100.1050	3200	1100	1050	930	1240	1860	300	500	2	2 x 36w
SPEH.BH.T2.3300.1100.1050	3300	1100	1050	960	1280	1920	300	500	2	2 x 36w
SPEH.BH.T2.3400.1100.1050	3400	1100	1050	990	1320	1980	300	500	2	2 x 36w
SPEH.BH.T2.3500.1100.1050	3500	1100	1050	1020	1360	2040	300	500	2	2 x 36w
SPEH.BH.T2.3600.1100.1050	3600	1100	1050	1050	1400	2100	300	500	2	2 x 36w
SPEH.BH.T2.3700.1100.1050	3700	1100	1050	1080	1440	2160	300	500	3	2 x 36w
SPEH.BH.T2.3800.1100.1050	3800	1100	1050	1110	1480	2220	300	500	3	2 x 36w
SPEH.BH.T2.3900.1100.1050	3900	1100	1050	1140	1520	2280	300	500	3	2 x 36w
SPEH.BH.T2.4000.1100.1050	4000	1100	1050	1170	1560	2340	300	500	3	2 x 36w
SPEH.BH.T2.4100.1100.1050	4100	1100	1050	1200	1600	2400	300	500	3	3 x 36w
SPEH.BH.T2.4200.1100.1050	4200	1100	1050	1230	1640	2460	300	500	3	3 x 36w
SPEH.BH.T2.4300.1100.1050	4300	1100	1050	1260	1680	2520	300	500	3	3 x 36w

Due to continuous product research and development, the information contained herein is subject to change without notification.