

Soak Sink-Mobile

The sink trolley is an entry-level product that easy to use, easy to clean and easy to drain by opening the integral stainless steel ball valve over a drain. The product is the culmination of years of experience in manufacturing and supplying dish handling and washing systems to Australian hospitals and other large Institutional customers. The system is the cleanest and easiest to operate, requiring no maintenance.

Model:

SPDH.ST.600

Code Explanation

SPDH	Standard Product Dish Handling
ST	Sink Trolley
600	Size

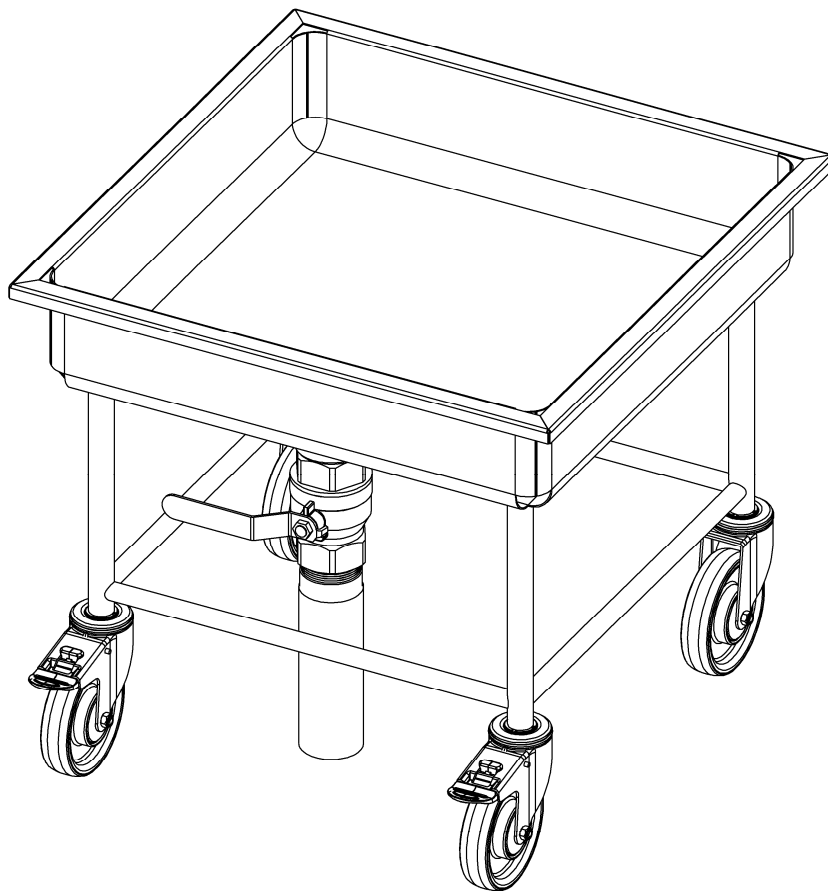

Features and Benefits:

- Stainless Steel 304 No4 1.5mm sink.
- 25mm radius internal corners to stainless steel sink to ensure bacteria does not grow in sharp corners. Easy to clean.
- 50mm Stainless Steel ball valve
- Stainless Steel 25mm round tube legs.
- 125mm swivel castors two with brakes.

Due to continuous product research and development, the information contained herein is subject to change without notification.

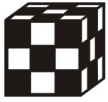

Soak Sink-Mobile

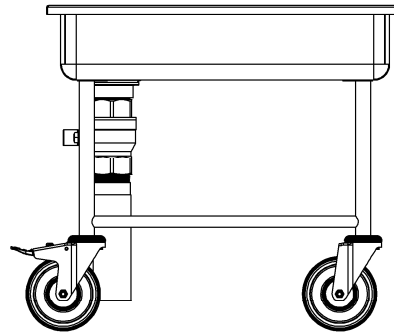
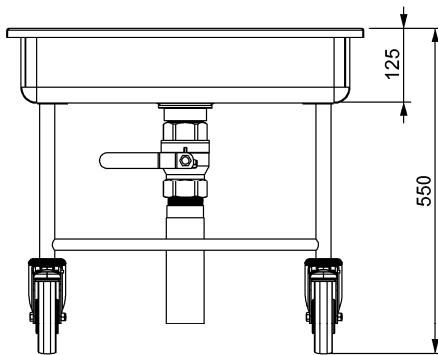
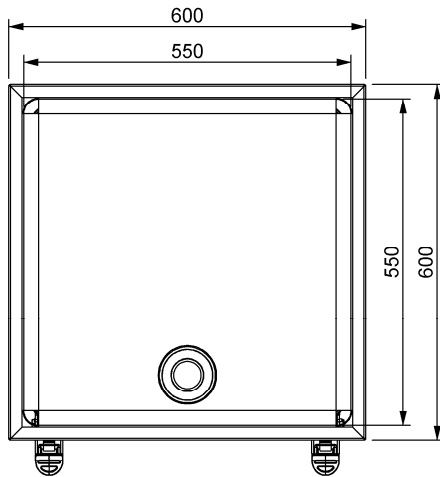

Due to continuous product research and development, the information contained herein is subject to change without notification.