

## Inlet Conveyor – Powered Carousel

The Culinaire® Carousel conveyor from Stoddart Manufacturing is the culmination of years of experience in manufacturing and supplying Warewash systems to Australian hospitals and other large institutional customers.

The system is the cleanest and the easiest to operate, requiring minimal maintenance.

It is available as part of a range of items to suit Warewash systems. Each work station is equipped with a stop button and an adjustable speed controller for varying systems.

### Models:

**SPDH.IC.PC.T2.zzzz**

Where:

SPDH	= Standard Product Dish Handling
IC	= Inlet Conveyor
PC	= Powered Carousel
T2	= Two Tier
zzzz	= Diameter

e.g.: for specification and ordering

Culinaire Model SPDH.IC.PC.T2.1800

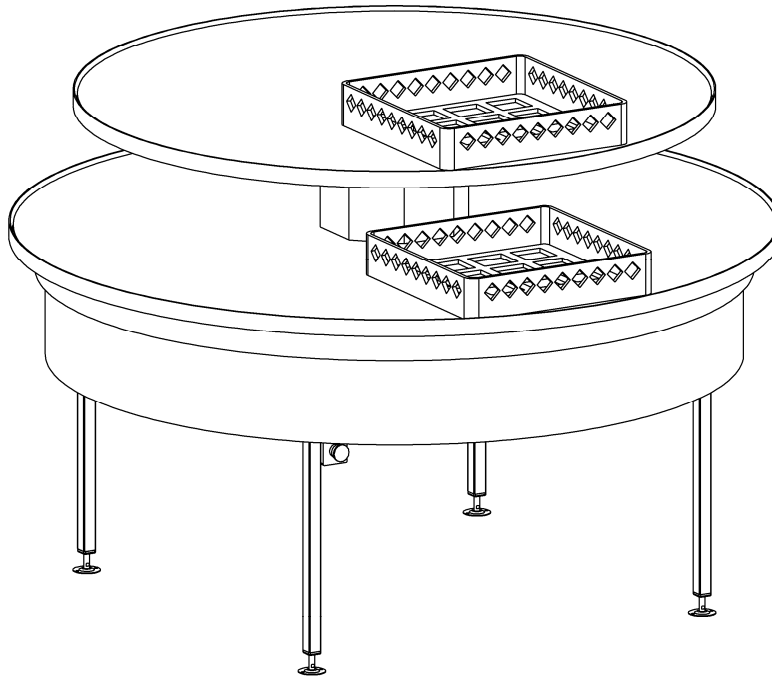

### Features and Benefits:

- Stainless Steel 304 No 4 construction throughout complete unit. 32x32 stainless steel legs and frame with adjustable feet.
- Stainless steel drive system bearings.
- Stainless steel cord drive belt adjustment system.
- Powerful electric motor and gearbox matched to suit conveyor, for years of trouble free service.
- Electronic variable speed and torque control for perfect speed matching to operator needs.
- Large industrial red mushroom head safety stop button and green 22mm diameter industrial start button at each operator location.
- The unit is tested to Australian Std AS3760 and manufactured in accordance with AS/NZS 60635.1

Due to continuous product research and development, the information contained herein is subject to change without notification.

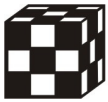

## Inlet Conveyor – Powered Carousel

### Standards

The Culinaire® Carousel conveyor from Stoddart Manufacturing is the culmination of years of experience in manufacturing and supplying Warewash systems to Australian hospitals and other large institutional customers.

The system is the cleanest and the easiest to operate, requiring minimal maintenance.

It is available as part of a range of items to suit Warewash systems. Each work station is equipped with a stop button and an adjustable speed controller for varying systems.

### Models:

**SPDH.IC.PC.T2.zzzz**

Where:

SPDH = Standard Product Dish Handling

IC = Inlet Conveyor

PC = Powered Carousel

T2 = Two Tier

zzzz = Diameter

e.g.: for specification and ordering

Culinaire Model SPDH.IC.PC.T2.1800

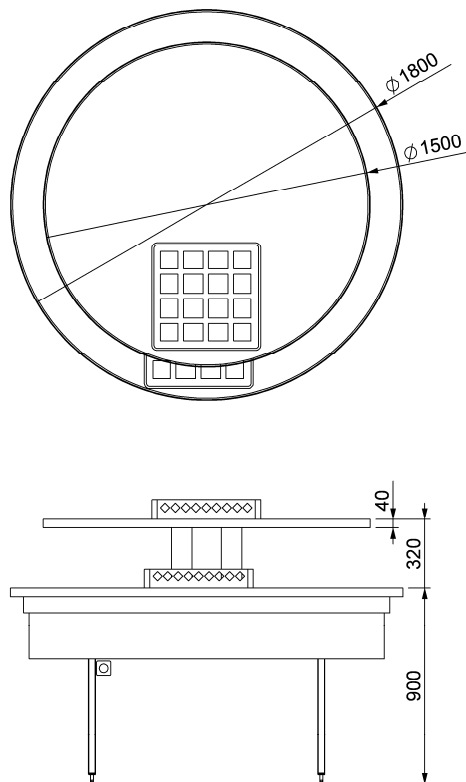

Model	Diameter (mm)	Total Electrical Load (watts)	415v 3A+N+E Amps/phase	Weight
SPDH-IC-PC-T2-1800	1800			
SPDH-IC-PC-T2-2400	2400			

Due to continuous product research and development, the information contained herein is subject to change without notification.

### Stoddart Manufacturing

Tom Stoddart Pty Ltd. ABN 16 009690251  
149 Jackson Road, Sunnybank Hills, Qld

Tel +61 7 33455011  
Fax +61 7 33441000  
Email: [sales@stoddart.com.au](mailto:sales@stoddart.com.au)  
Web: [www.stoddart.com.au](http://www.stoddart.com.au)

Printed date 27/02/2009  
Revision Date 26/02/09