

Inlet Cord Conveyor – Drive-900

The Culinaire® cord inlet conveyor from Stoddart Manufacturing is the culmination of years of experience in manufacturing and supplying stripping systems to Australian hospitals and other large institutional customers.

The system is the cleanest and to easiest to operate, requiring minimal maintenance.

It is available in two lengths'.

Models:

SPDH.IC.C.SS.D.900

Where:

SPDH	= Standard Product Dish Handling
IC	= Inlet Conveyor
C	= Cord
SS	= Straight Stripping
L	= Length Std lengths 900mm 1200mm

e.g.: for specification and ordering

Culinaire Model SPDH.IC.C.SS.D.900

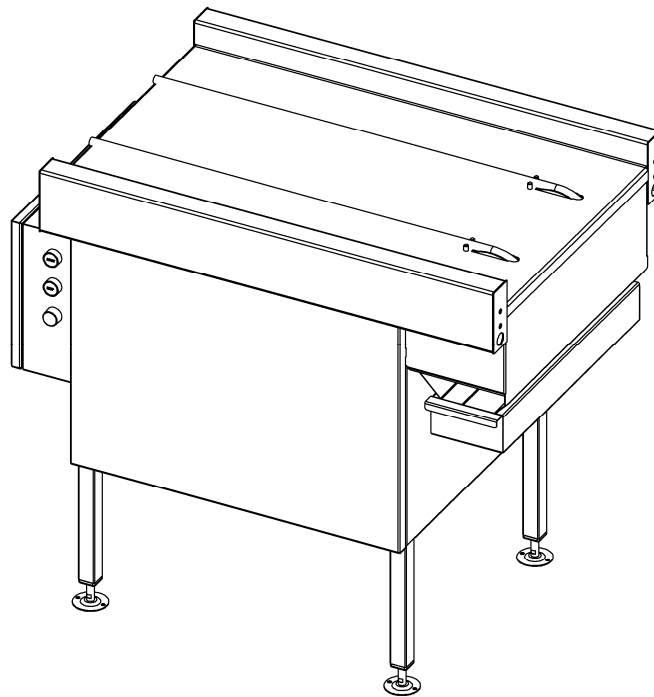

Features and Benefits:

- Stainless Steel 304 No 4 construction throughout complete unit. 32x32 stainless steel legs and frame with adjustable feet.
- Stainless steel drive system bearings and cord drive rollers.
- Stainless steel cord drive belt's adjustment system.
- Powerful electric motor and gearbox matched to suit conveyor length for years of trouble free service.
- Electronic variable speed and torque control for perfect speed matching to operator needs.
- Large industrial red mushroom head safety stop button and green 22mm diameter industrial start button at each operator location.
- 240 volt 10 amp single phase power supply.
- Removable panels to the motor-gearbox drive enclosure.
- The 15mm diameter cord conveyor belt is joined using an extremely strong welded connection
- The large diameter cord creates more space below the meal trays, allowing the operators fingers to easily fit under the tray when lifting it off the conveyor.
- The unit is tested to Australian Std AS3760 and manufactured in accordance with AS/NZS 60635.1

Due to continuous product research and development, the information contained herein is subject to change without notification.

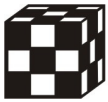

Inlet Cord Conveyor – Drive-900

Models:

SPDH.IC.C.SS.D.900

Where:

- SPDH = Standard Product Dish Handling
- IC = Inlet Conveyor
- C = Cord
- Ss = Straight Stripping
- L = Length
Std lengths 900mm
1200mm

e.g.: for specification and ordering

Culinaire Model SPDH.IC.C.SS.D.900

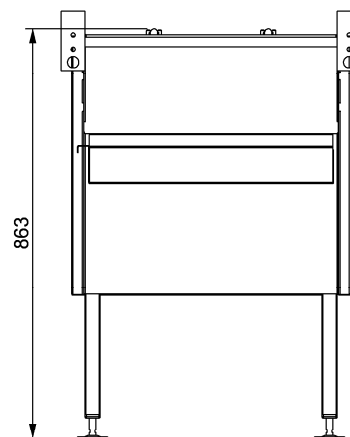
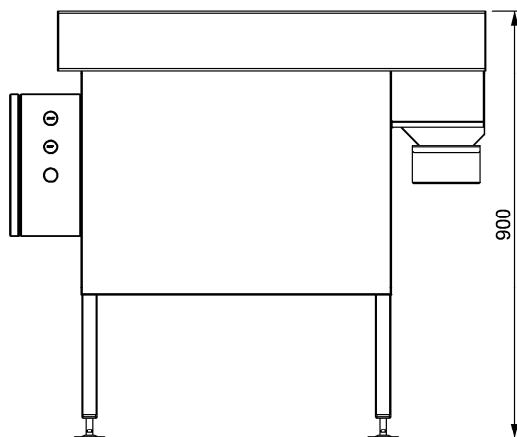
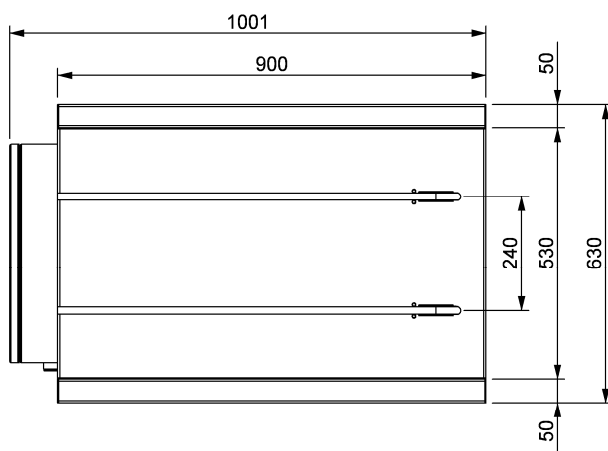

Model	Length (mm)	Total Electrical Load (watts)	240v Amps	Weight
SPDH.IC.C.SS.D.900	900 mm	2400	10	
SPDH.IC.C.SS.D.1200	1200mm	2400	10	

Due to continuous product research and development, the information contained herein is subject to change without notification.