

## Gravity Roller Stripping Station

The scrapping and sorting non powered conveyor is an entry level product that when coupled to a rack type dishwasher makes the pre-scrapping task easier and quicker.

The product is the culmination of years of experience in manufacturing and supplying dish handling and washing systems to Australian hospitals and other large Institutional customers.

The system is the cleanest and to easiest to operate, requiring no maintenance.

It is available in a range of lengths to suit the number of persons working on the scrapping line.

### Models:

**SPDH.IC.GR.SS.L.W.Z**

Where:

SPDH = Standard Product Dish Handling

IC = Inlet Conveyor

GR = Gravity Roller

SS = Stripping Station

L = Length

Std lengths 4000mm – suits 4 persons

5000mm – suits 6 persons

6000mm – suits 8 persons

W = Width (Std 1050mm)

Z = R right to left operation

= L left to right operation

e.g.: SPDH.IC.GR.SS.3185.1050.R

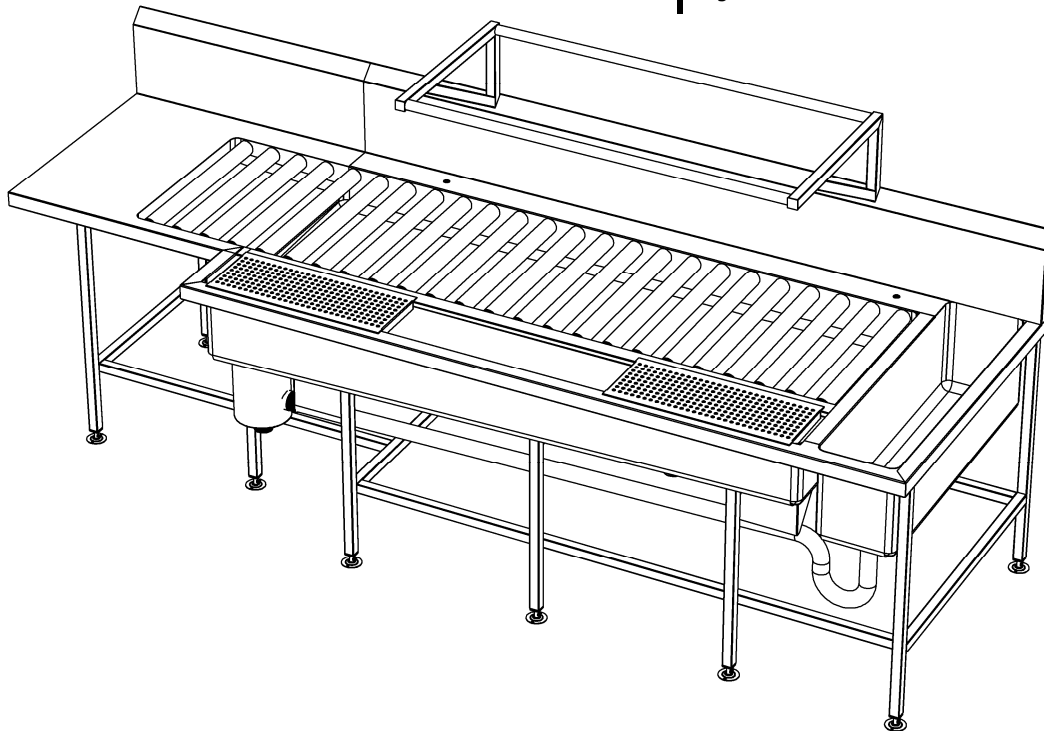

### Features and Benefits:

- Stainless Steel 304 No 4 construction throughout complete unit. 32x32 stainless steel legs and frame with adjustable feet.
- Stainless steel drive system bearings and cord drive rollers.
- Stainless steel cord drive belt adjustment system.
- Powerful electric motor and gearbox matched to suit conveyor length for years of trouble free service.
- Electronic variable speed and torque control for perfect speed matching to operator needs.
- Large industrial red mushroom head safety stop button and green 22mm diameter industrial start button at each operator location.
- 240 volt 15 amp GPO at each operator location to allow mobile food serving carts and heated plate storage carts to be powered in easy reach of each operator.
- Lockable Doors to the motor-gearbox drive enclosure.
- The 16mm diameter cord conveyor belt is joined using an extremely strong welded connection
- The large diameter cord creates more space below the meal trays, allowing the operators fingers to easily fit under the tray when lifting it off the conveyor.

Due to continuous product research and development, the information contained herein is subject to change without notification.

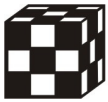

## Gravity Roller Stripping Station

**Models:**

**SPDH.IC.GR.SS.L.W.Z**

Where:

SPDH = Standard Product Dish Handling

IC = Inlet Conveyor

GR = Gravity Roller

SS = Stripping Station

L = Length

Std lengths 4000mm – suits 4 persons

5000mm – suits 6 persons

6000mm – suits 8 persons

W = Width (Std 1050mm)

Z = R right to left operation

= L left to right operation

e.g.: SPDH.IC.GR.SS.3185.1050.R

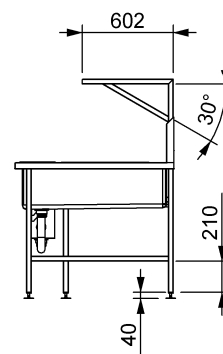
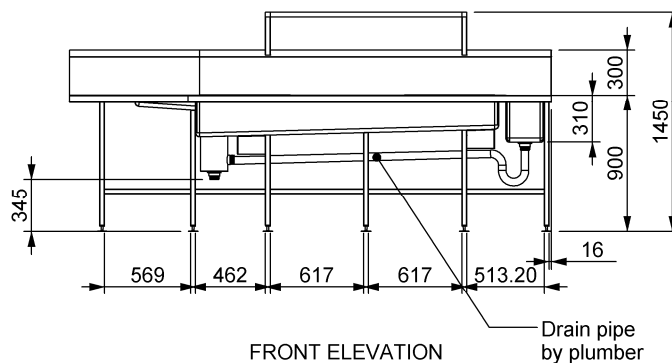
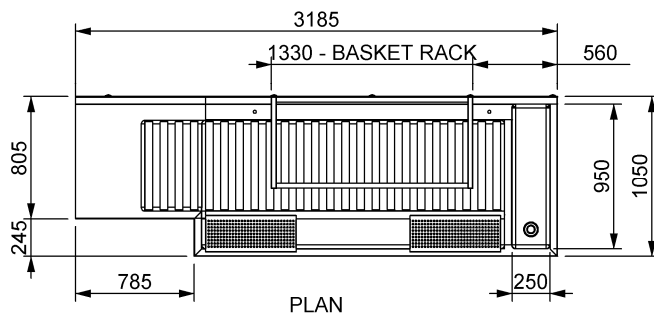

Due to continuous product research and development, the information contained herein is subject to change without notification.