

**Product Details**

Electrical Connection : 20Amp Single Phase, Hard Wired  
 Electrical Rating : 240V, 20A, 4800W  
 : 2 fan forced heating units @ 2400W  
 Unit Controls : Switch for optional gantry  
 : Switch for hotcupboard with electronic thermostat  
 Door Opening : 425 x 578 (Ends)  
 : 331 x 578 (Middle)

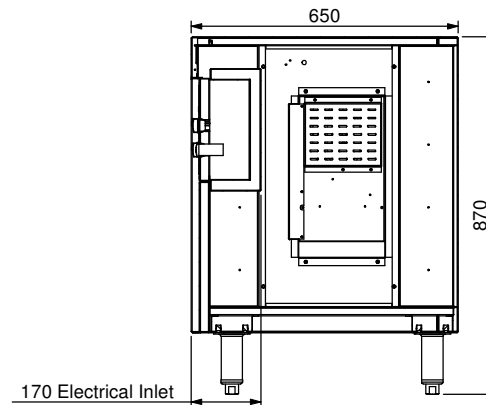
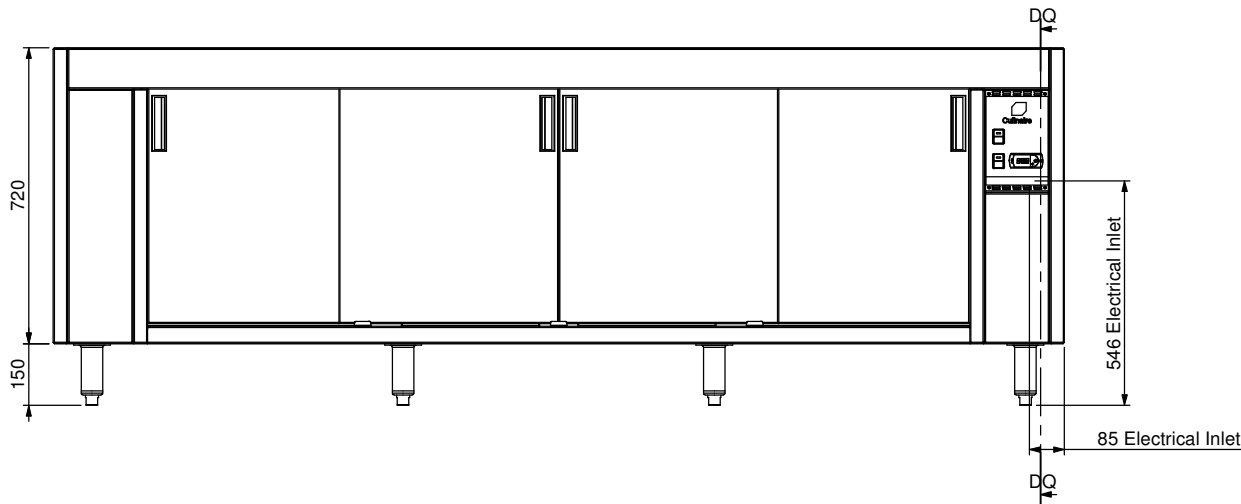
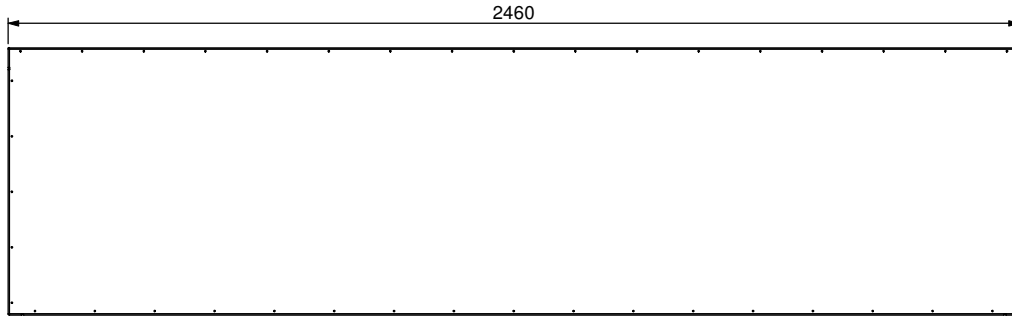
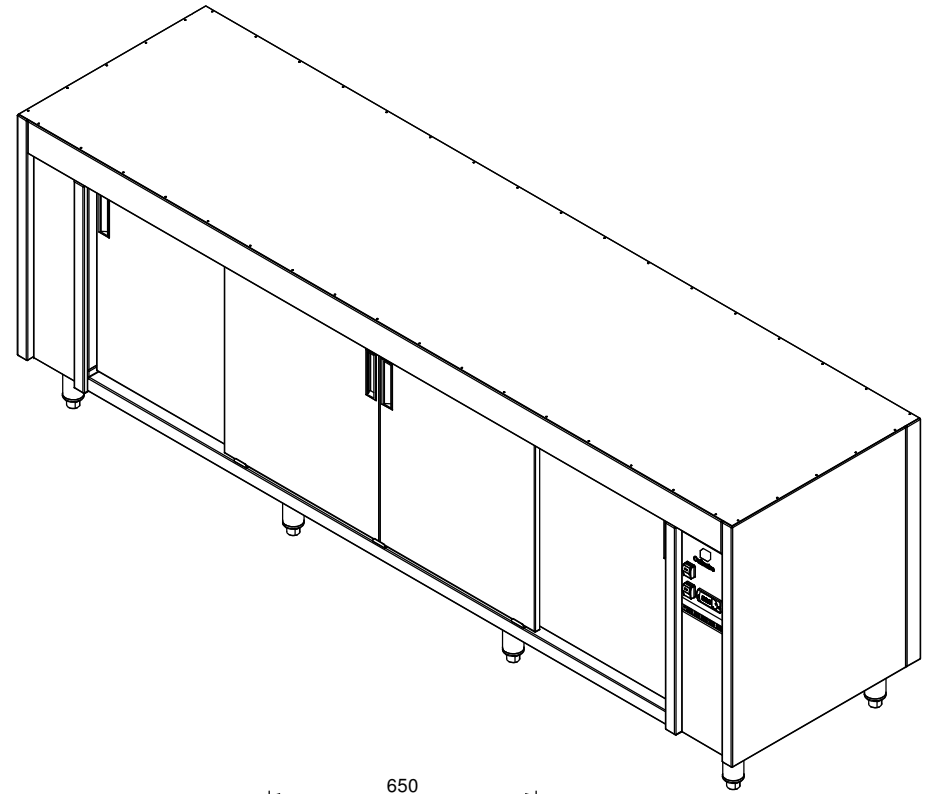

SECTION DQ-DQ

Press:	Programmed by:	Date:	Punch:	Die:
--------	----------------	-------	--------	------

**STODDART**  
 METAL FABRICATORS  
 TOM STODDART Pty Ltd ACN 009 690 251  
 215 Jackson Rd Sunnybank Hills Qld 4109  
 PO Box 420 Sunnybank Qld 4109  
 Phone (617) 3345 5011 Fax (617) 3344 1000  
 Email sunnybank@stoddart.com.au  
*Quality in stainless steel*

PRODUCT: 7 Mod Undercounter Hotcupboard				PART No: <b>CHC7-U-A001</b>	
DRAWN	N Wooler	SIGNATURE	DATE	UNLESS OTHERWISE SPECIFIED: DIMENSIONS ARE IN MILLIMETERS	
APPVD				DESCRIPTION: General Drawing	
			MATERIAL:		REVISION
			THICKNESS:		
			FINISH:		
DO NOT SCALE DRAWING		This drawing remains the property of Tom Stoddart Pty Ltd & cannot be reproduced without prior permission.			A3
				Sheet 1 of 42	