

| ITEM NO. | PART NUMBER | DESCRIPTION | Spare Parts/QTY. |
|----------|-------------|--|------------------|
| 34 | CMGE-0415 | 385 x 500 Shelf | 1 |
| 35 | CMGE-0416 | 550 x 500 Shelf | 2 |
| 36 | FFHE-A001 | Fan Forced Heating Enclosure | 1 |
| 37 | CMGE- 0156 | Adj Foot; 150 High; 50 Dia; with plate | 6 |
| 38 | CMGE-0258 | Castor;125mm;Swivel Plate;Total Brake | 6 |
| 39 | C MEL-0934 | Carel Controller PYEZONM011 | 1 |
| 40 | C MEL-0668 | Sonar Switch | 2 |

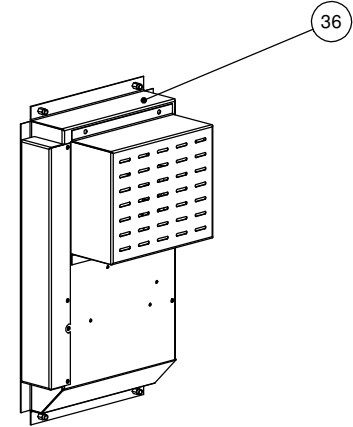
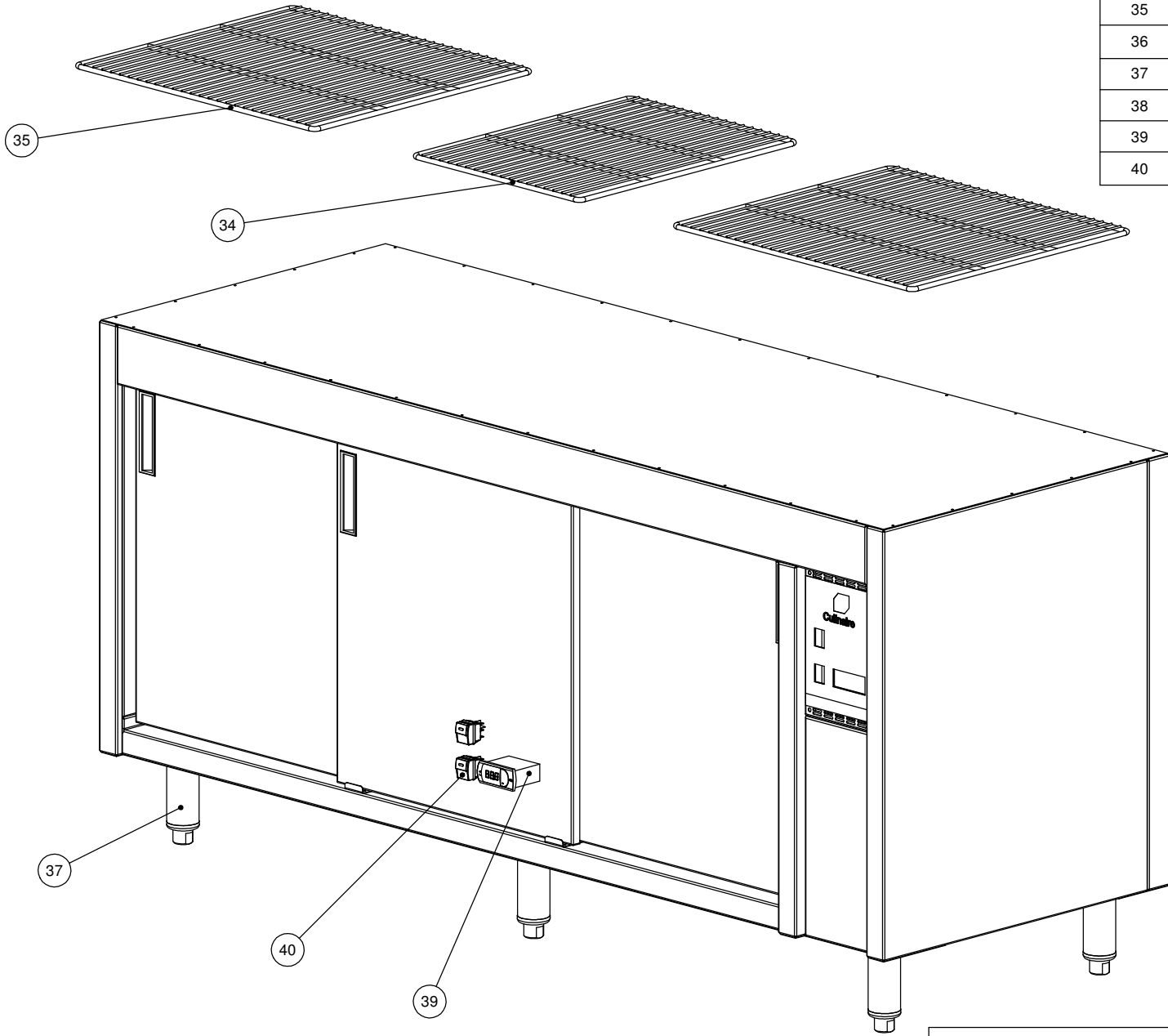

| | | | | |
|--------|----------------|-------|--------|------|
| Press: | Programmed by: | Date: | Punch: | Die: |
|--------|----------------|-------|--------|------|

STODDART
METAL FABRICATORS
TOM STODDART Pty Ltd ACN 009 690 251
215 Jackson Rd Sunnybank Hills Qld 4109
PO Box 420 Sunnybank Qld 4109
Phone (617) 3345 5011 Fax (617) 3344 1000
Email sunnybank@stoddart.com.au
Quality in stainless steel

| | | | | | |
|---|----------|-----------|------|--|----------|
| PRODUCT: 5 Mod Undercounter Hotcupboard | | | | PART No: CHC5-U-A001 | |
| DRAWN | N Wooler | SIGNATURE | DATE | UNLESS OTHERWISE SPECIFIED: DIMENSIONS ARE IN MILLIMETERS | |
| APPV'D | | | | DESCRIPTION: Spare Parts | |
| | | | | MATERIAL: | REVISION |
| | | | | THICKNESS: | |
| | | | | FINISH: | |
| | | | | DWG No: CHC5-U-D001 | |
| | | | | Sheet 3 of 45 | |
| DO NOT SCALE DRAWING | | | | This drawing remains the property of Tom Stoddart Pty Ltd & cannot be reproduced without prior permission. | |

| REV. | NAME | DATE | DESCRIPTION |
|------|-----------|------------|-------------------------------------|
| B | M Sheehan | 25/03/2008 | Dixell controller replaced by Carel |