

ITEM NO.	PART NUMBER	DESCRIPTION	Spare Parts/QTY.
32	CMGE-0415	385 x 500 Shelf	2
33	FFHE-A001	Fan Forced Heating Enclosure	1
34	CMGE- 0156	Adj Foot; 150 High; 50 Dia; with plate	4
36	CMEL-0934	Carel Controller PYEZONM011	1
37	CMEL-0668	Sonar Switch	2

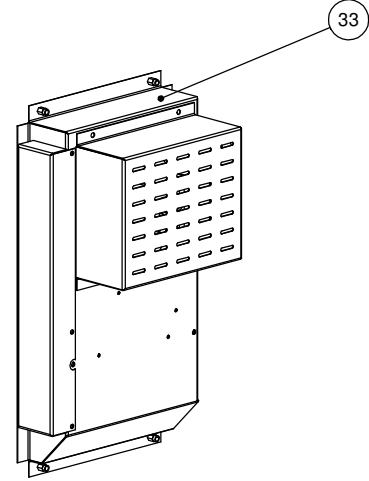
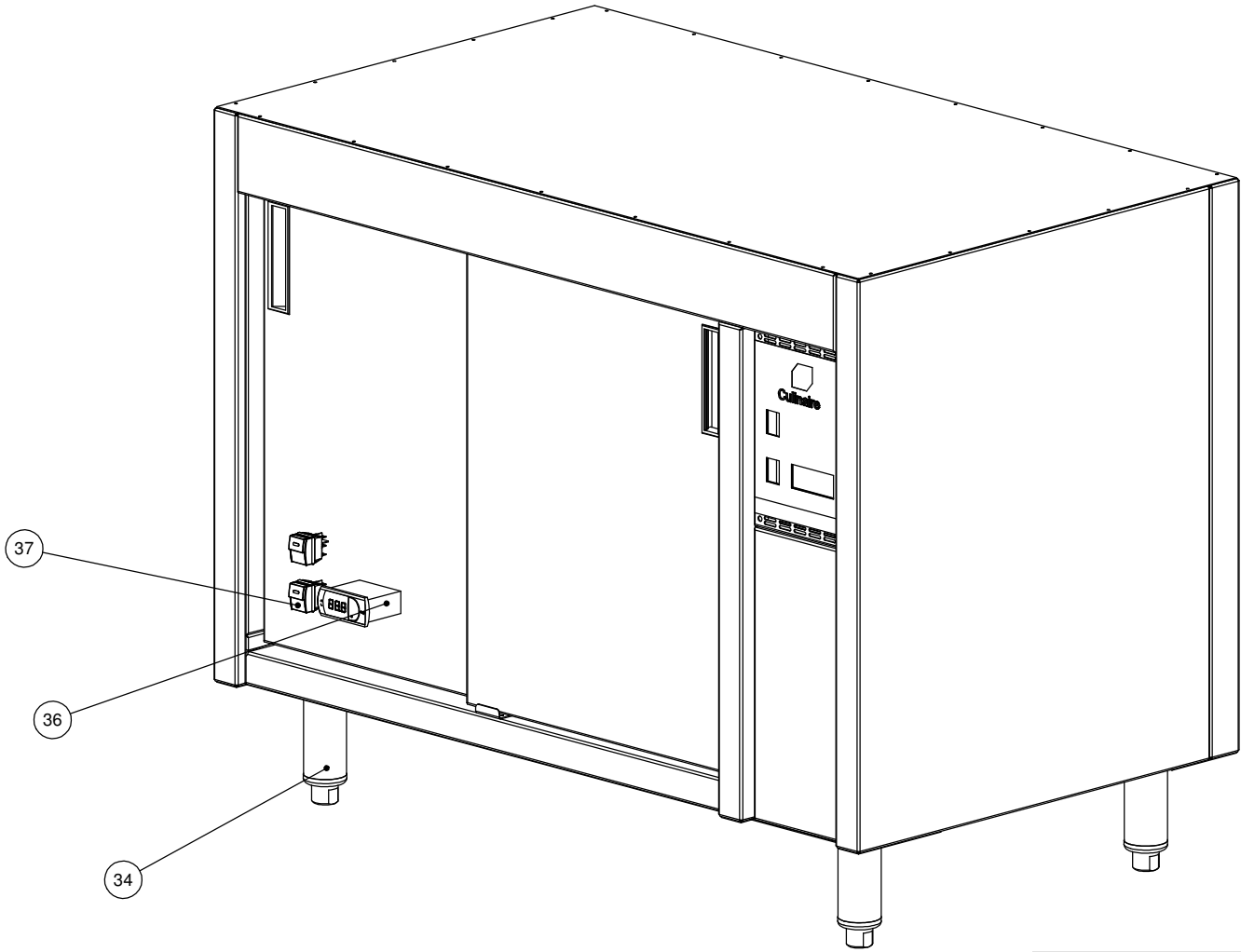
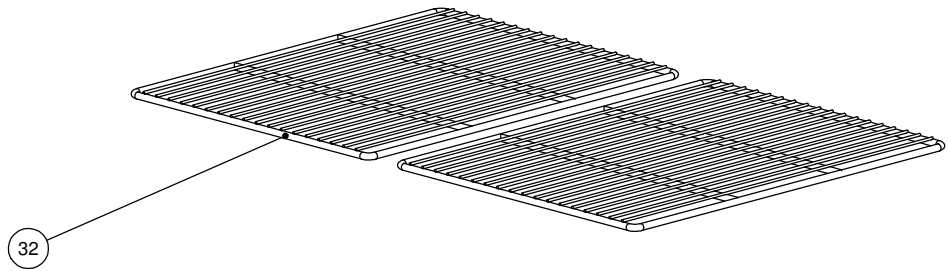

Press:	Programmed by:	Date:	Punch:	Die:
--------	----------------	-------	--------	------

STODDART
METAL FABRICATORS
 TOM STODDART Pty Ltd ACN 009 690 251
 215 Jackson Rd Sunnybank Hills Qld 4109
 PO Box 420 Sunnybank Qld 4109
 Phone (617) 3345 5011 Fax (617) 3344 1000
 Email sunnybank@stoddart.com.au
Quality in stainless steel

PRODUCT: 3 Mod Undercounter Hotcupboard				PART No: CHC3-U-A001	
DRAWN	N Wooler	SIGNATURE	DATE	UNLESS OTHERWISE SPECIFIED: DIMENSIONS ARE IN MILLIMETERS	
APPVD				DESCRIPTION: Spare Parts	
			MATERIAL:	REVISION	
			THICKNESS:	DWG No: CHC3-U-D001	
			FINISH:	B	
DO NOT SCALE DRAWING		This drawing remains the property of Tom Stoddart Pty Ltd & cannot be reproduced without prior permission.			A3
					Sheet 3 of 42

REV.	NAME	DATE	DESCRIPTION
B	M Sheehan	26/03/2008	Dixell controller replaced by Carel