

Product Details

- Electrical Connection : Supply 3 phase + Neutral + Earth
- : 240V, 30amps, 6900w, Hard Wired
- : 6 elements @ 750w (240V)
- : 1 fan forced heating unit @ 2400w (240V)
- : 40mm with 1 1/2" BSP ball valve
- Waste
- Overflow
- Water Connection : 1/2" BSP ball valve
- Unit Controls : Switch for bain marie with electronic thermostat
- : Switch for hotcupboard with electronic thermostat
- Door Opening : 555 x 421 (Ends),
- : 540 x 421 (Middle)

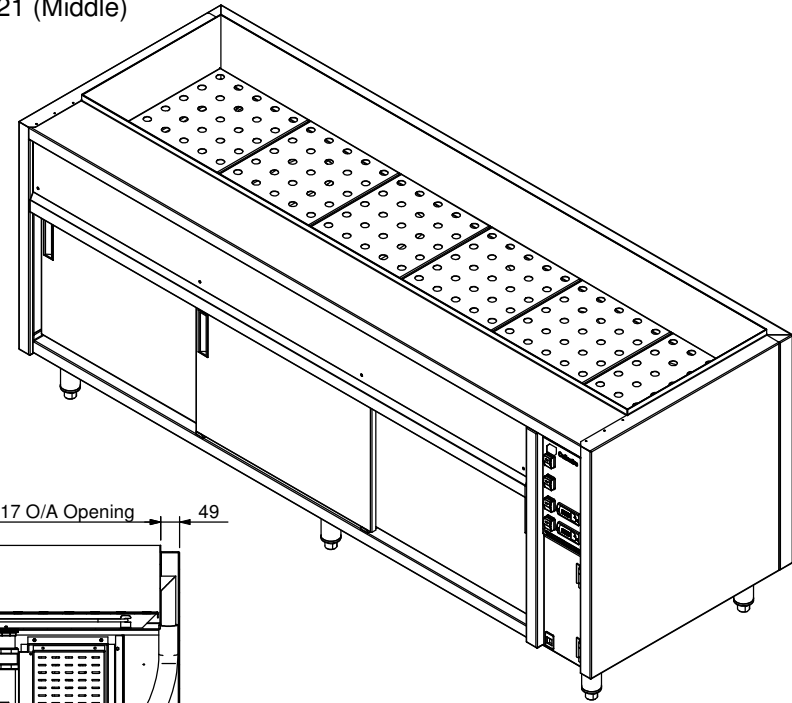
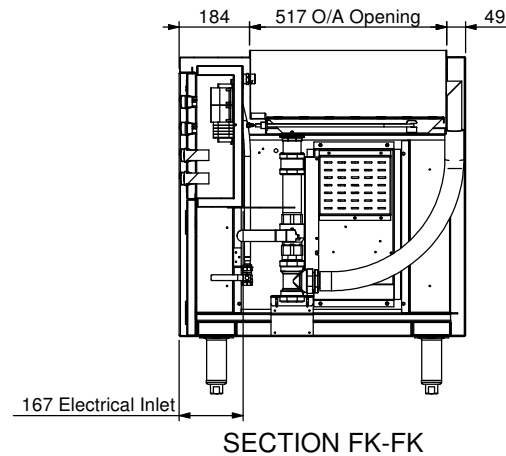
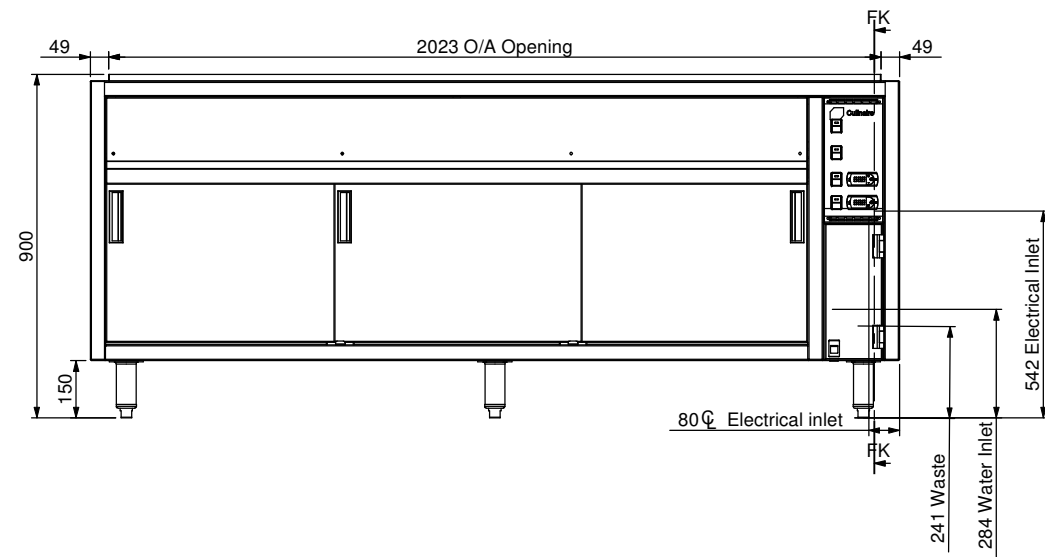
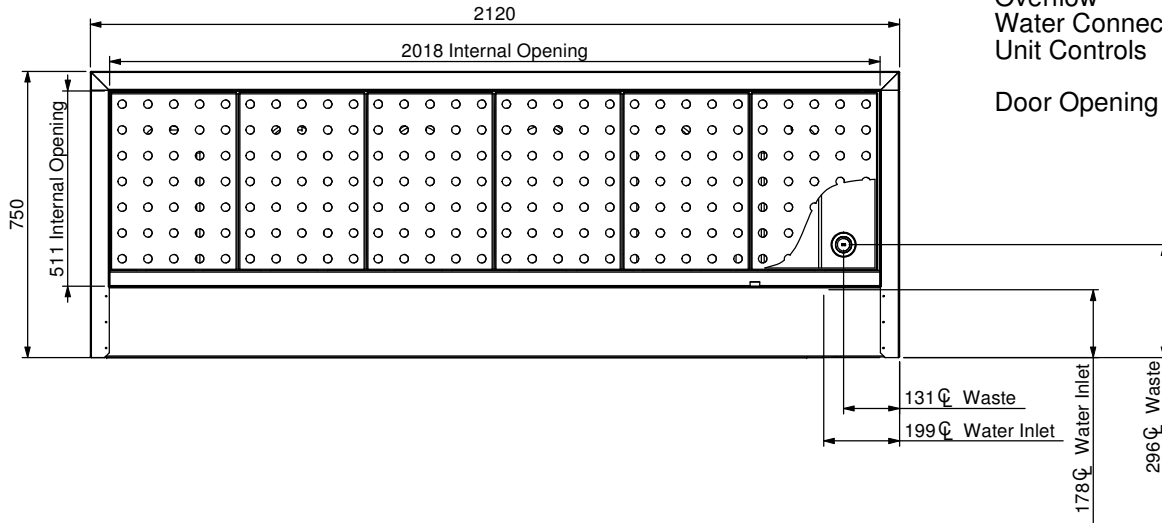

REV.	NAME	DATE	DESCRIPTION
B	N Wooler	15/09/2006	Latest changes implemented

STODDART
METAL FABRICATORS
TOM STODDART Pty Ltd ACN 009 690 251
215 Jackson Rd Sunnybank Hills Qld 4109
PO Box 420 Sunnybank Qld 4109
Phone (617) 3345 5011 Fax (617) 3344 1000
Email sunnybank@stoddart.com.au
Quality in stainless steel

Press:	Programmed by:	Date:	Punch:	Die:
PRODUCT: 6 Mod Underbench Bain Marie Hotcupboard		PART No: CBMH6-U-A001		
DRAWN: N Wooler	SIGNATURE:	DATE: 2/09/2008	UNLESS OTHERWISE SPECIFIED: DIMENSIONS ARE IN MILLIMETERS	
APPVD:	MATERIAL: 304 No 4 S/S		DESCRIPTION: General Drawing	
DO NOT SCALE DRAWING		THICKNESS: FINISH: No 4	DWG No: CBMH6-U-D001	REVISION: B
This drawing remains the property of Tom Stoddart Pty Ltd & cannot be reproduced without prior permission.			A3	Sheet 1 of 61