

ITEM NO.	PART NUMBER	DESCRIPTION	Spare Parts/QTY.
35	CMGE-0419	550 x 600 Shelf	2
38	CUL-P003	Element Cover	4
41	CMEL-0260	750w element	4
45	CMEL-0668	Sonar Switch	4
46	CMEL-0934	Carel Controller PYEZONM011	2
50	FFHE-A001	Fan Forced Heating Enclosure	1

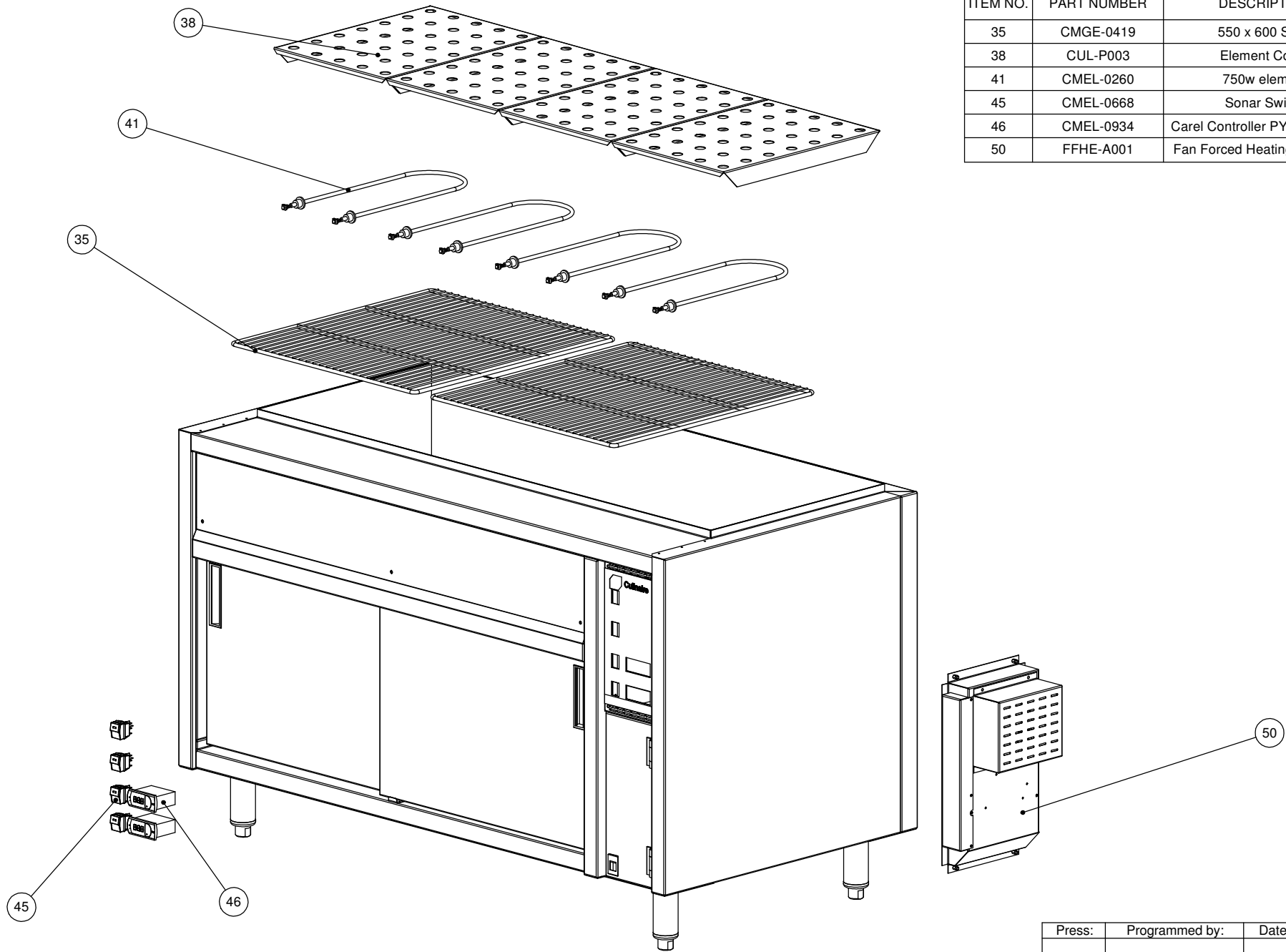

REV.	NAME	DATE	DESCRIPTION
D	M Sheehan	26/02/2008	Dixell controllers replaced by Carel
C	N Wooler	31/08/2006	Latest changes implemented
B	N Wooler	29/06/2005	Redesigned unit

**STODDART**  
 METAL FABRICATORS  
 TOM STODDART Pty Ltd ACN 009 690 251  
 215 Jackson Rd Sunnybank Hills Qld 4109  
 PO Box 420 Sunnybank Qld 4109  
 Phone (617) 3345 5011 Fax (617) 3344 1000  
 Email [sunnybank@stoddart.com.au](mailto:sunnybank@stoddart.com.au)  
*Quality in stainless steel*

Press: _____ Programmed by: _____ Date: _____ Punch: _____ Die: _____			
PRODUCT: <b>4 Mod Underbench Bain Marie Hotcupboard</b>			PART No: <b>CBMH4-U-A001</b>
DRAWN: N Wooler APPVD: _____	NAME: _____ SIGNATURE: _____ DATE: 1/09/2008	UNLESS OTHERWISE SPECIFIED: DIMENSIONS ARE IN MILLIMETERS	DESCRIPTION: Spare Parts
MATERIAL: 304 No 4 S/S THICKNESS: _____ FINISH: No 4		DWG No: <b>CBMH4-U-D001</b>	REVISION: <b>D</b>
DO NOT SCALE DRAWING This drawing remains the property of Tom Stoddart Pty Ltd & cannot be reproduced without prior permission.			A3 Sheet 3 of 59