

**Product Details**

Electrical Connection : 10Amp Plug and Lead  
 Electrical Rating : 240V, 7A, 1680W  
 : 4 x 250W Heater Pads (side panels)  
 : 1 x 340W Heater Pad (base panel)  
 : 1 x 340W Heater Pad (rear panel)  
 Unit Controls : Switch with electronic thermostat

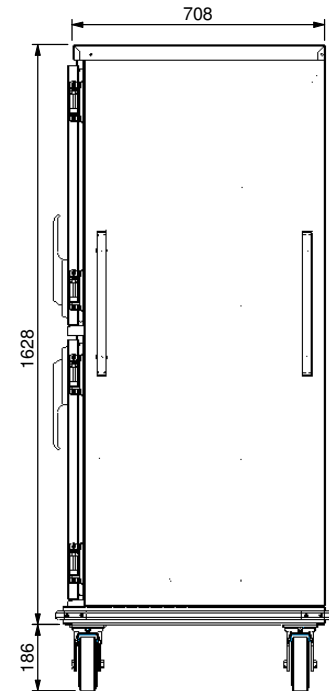
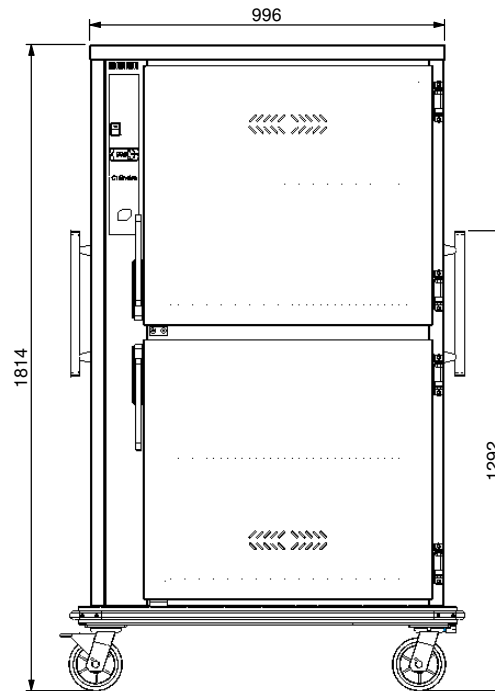
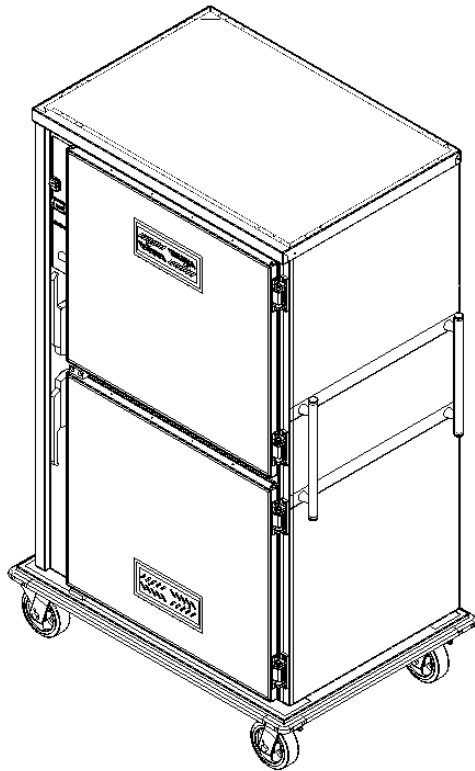
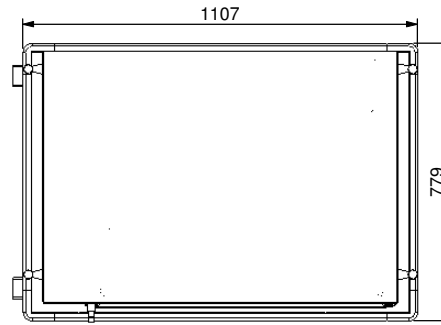

REV.	NAME	DATE	DESCRIPTION
D	M Sheehan	30/07/2007	Rear heating panel added
C	C Johnson	15/09/2006	Venting for control panel added, supports for insulation added
B	D Bowden	29/06/2006	O/A height change, internal cabinet length change, probe recess added

**STODDART**  
 METAL FABRICATORS  
 TOM STODDART Pty Ltd ACN 009 690 251  
 215 Jackson Rd Sunnybank Hills Qld 4109  
 PO Box 420 Sunnybank Qld 4109  
 Phone (617) 3345 5011 Fax (617) 3344 1000  
 Email sunnybank@stoddart.com.au  
*Quality in stainless steel*

Press:      Programmed by:      Date:      Punch:      Die:			
PRODUCT: <b>96 Plate Banquet Cart</b>			
PART No: <b>CBC96-A001</b>		DESCRIPTION: <b>General Drawing</b>	
DRAWN N Wooler	SIGNATURE	DATE 27/08/2004	UNLESS OTHERWISE SPECIFIED: DIMENSIONS ARE IN MILLIMETERS
APPVD	MATERIAL: THICKNESS: FINISH:	DWG No: <b>CBC96-D001</b>	REVISION <b>D</b>
DO NOT SCALE DRAWING	This drawing remains the property of Tom Stoddart Pty Ltd & cannot be reproduced without prior permission.		A3      Sheet 1 of 49