

Product Details

Electrical Connection : 10Amp Plug & Lead (supplied)
 Electrical Rating : 240V, 7A, 1680W
 : 4 heater pads @ 250W (side panels)
 : 1 heater pad @ 340W (rear panel)
 : 1 heater pad @ 340W (base panel)
 Unit Controls : Switch for power with electronic thermostat

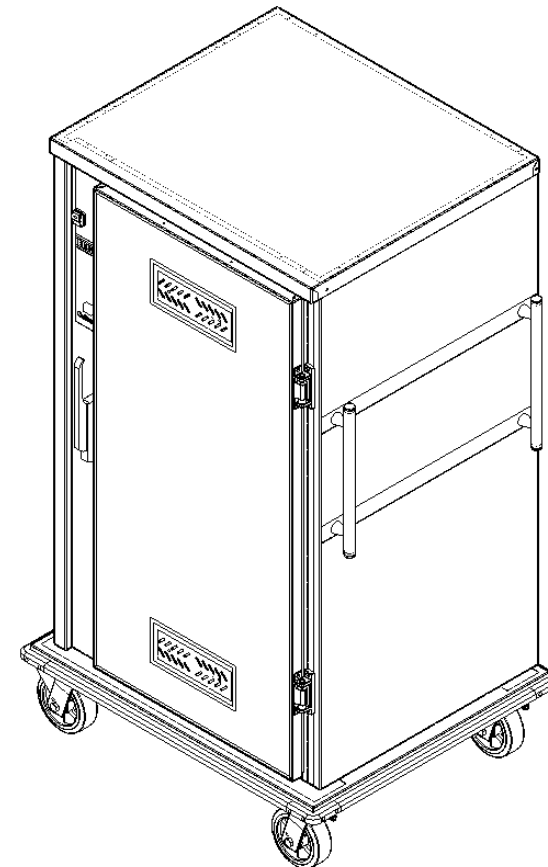
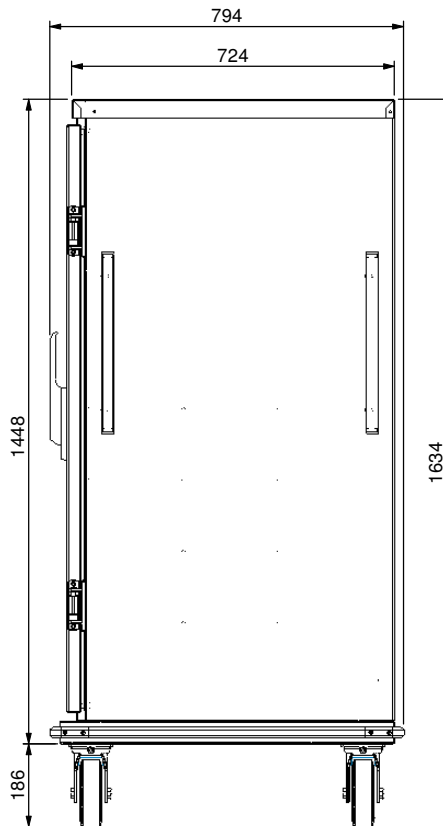
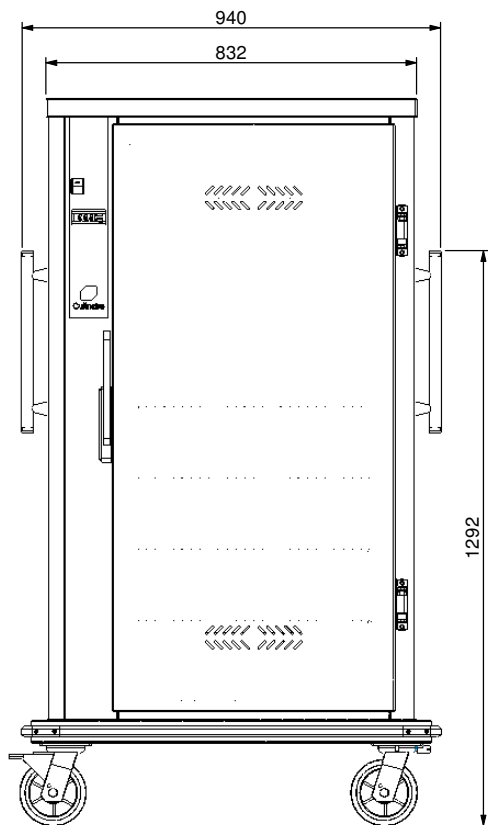

REV.	NAME	DATE	DESCRIPTION
F	M Sheehan	14/08/2007	Cabinet width changed, rear heater panel added, heating pad configuration changed
E	D Bowden	14/03/2006	Vent changed to standard
D	D Bowden	3/02/2006	Configuration added for dixell control cover

STODDART
 METAL FABRICATORS
 TOM STODDART Pty Ltd ACN 009 690 251
 215 Jackson Rd Sunnybank Hills Qld 4109
 PO Box 420 Sunnybank Qld 4109
 Phone (617) 3345 5011 Fax (617) 3344 1000
 Email sunnybank@stoddart.com.au
Quality in stainless steel

PRODUCT: Gastronorm Banquet Cart				PART No: CBC2611-A001	
DRAWN	N Wooler	SIGNATURE	DATE	UNLESS OTHERWISE SPECIFIED: DIMENSIONS ARE IN MILLIMETERS	
APPVD				DESCRIPTION: General Drawing	
			MATERIAL:		REVISION
			THICKNESS:		F
			FINISH:		
DO NOT SCALE DRAWING				This drawing remains the property of Tom Stoddart Pty Ltd & cannot be reproduced without prior permission.	
				A3	Sheet 1 of 45

Press:	Programmed by:	Date:	Punch:	Die:
--------	----------------	-------	--------	------